

# AOPEC

## Voltage Sensitive Relay

| Extend Battery Life



### Features

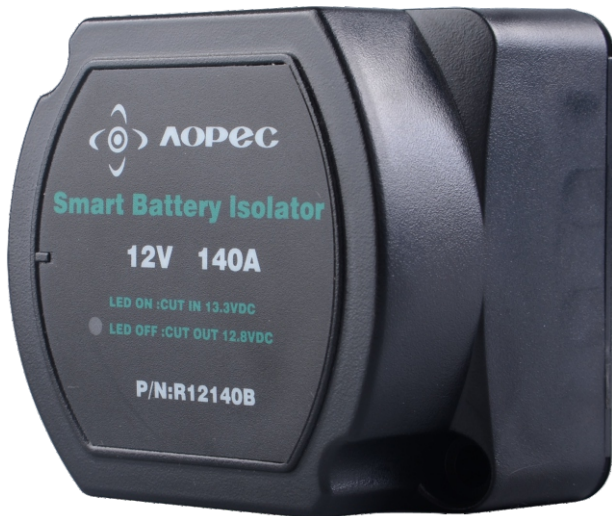

- 12V,140A/24V,100A ;
- Designed for dual battery system ;
- For 12V/24V charging system ;
- Surge protection ;
- Dashboard reminder function ;
- Forced manual Cut in function ;
- MCU control, Cut in &Cut out voltage can be set by customer ;
- Easy to install.

## Voltage Sensitive Relay

### Wiring Diagram

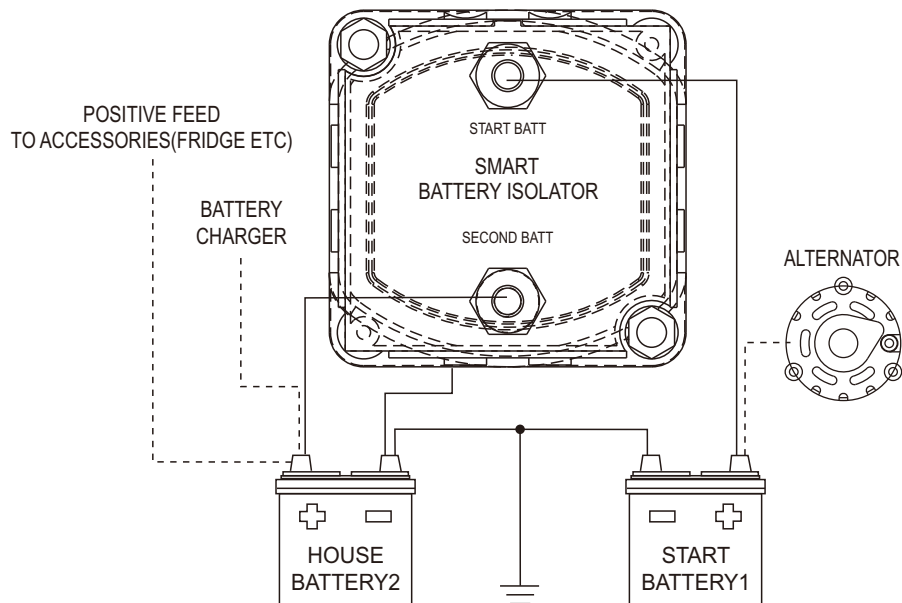

## Perfect For

**BSR is widely used for :**

Business RVs,  
Ambulances,  
Special police  
vehicles,  
Pickups, ATVs,  
Yachts,  
Heavy trucks,  
Engineering  
trucks, etc.

**APPLICATIONS**  
Charge your battery better!



## Voltage Sensitive Relay

### BSR Product List

Part Number	Rated voltage	Rated current	Gap current	Cut in	Cut out
R12140A	12V	140A	170A	13.7V	12.8V
R24100A	24V	100A	140A	27.4V	25.6V
R12140B	12V	140A	170A	13.3V	12.8V
R24100B	24V	100A	140A	26.6V	25.6V
R12140C-1 R12140C-2	12V	140A	170A	13.3V	12.8V
R24100C-1 R24100C-2	24V	100A	140A	27.4V	25.6V
R12140E	12V	140A	170A	13.2V	12.7V
R12140X	12V	140A	170A	Set by need	Set by need
R24100X	24V	100A	140A	Set by need	Set by need

Note: R12140X & R24100X are new BSR models.

## Dual Battery Kits

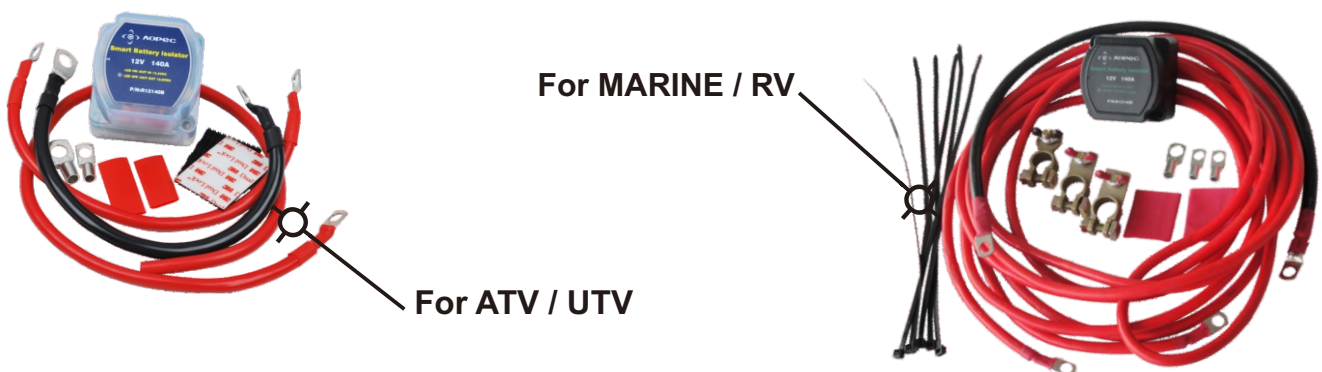

## Voltage Sensitive Relay

### How Does It Work?

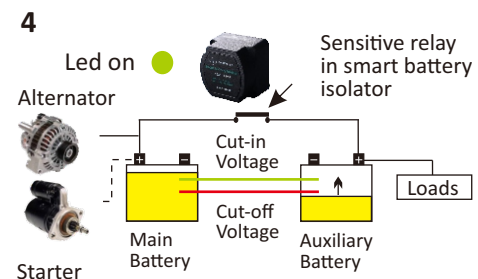
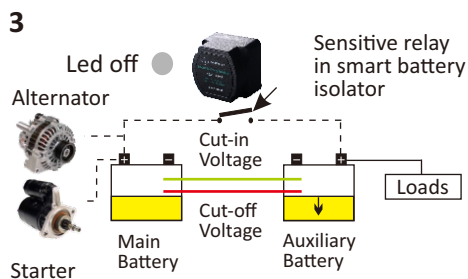
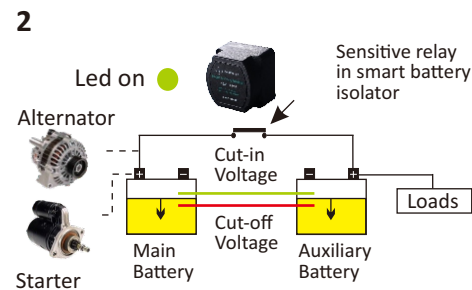
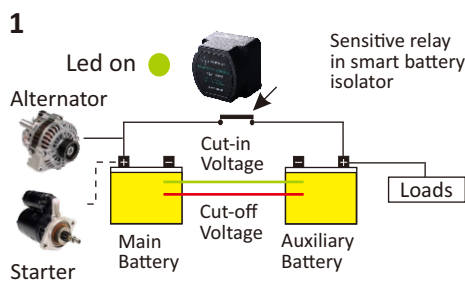

1. When the voltage of start battery is higher than cut-in volts, the smart battery isolator (SBI) keeps engaging, two batteries (start and house) are charged simultaneously. Unit Indicator (LED) is on.
2. When the batteries no longer have a charge from the alternator, and loads on the batteries begin to deplete them. Unit Indicator (LED) is on.
3. When the voltage drops below cut-off volts for 5 seconds, the SBI senses it and disengages, separating both batteries. Unit Indicator (LED) is off.
4. When the vehicle is restarted, the start battery has reached the cut-in volts, the SBI engaged again. Unit Indicator (LED) is on.

## Voltage Sensitive Relay

### Dimensiones

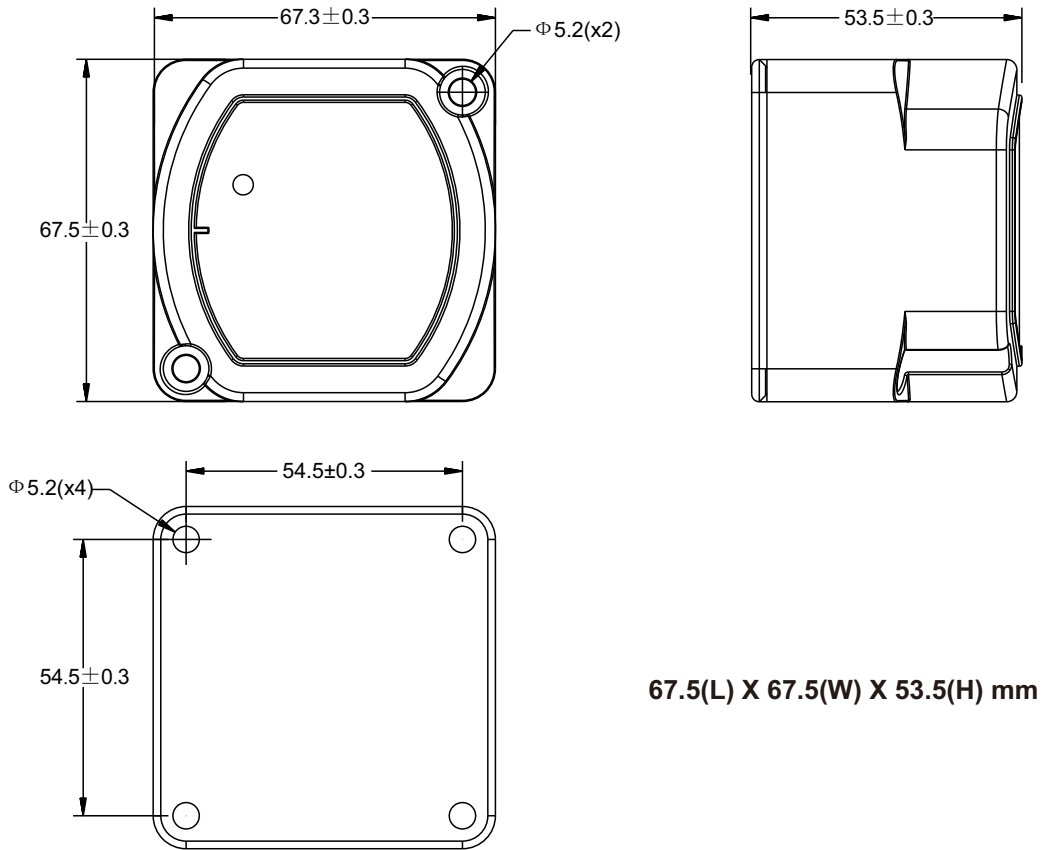

## Certificates



**IATF**



**CE**

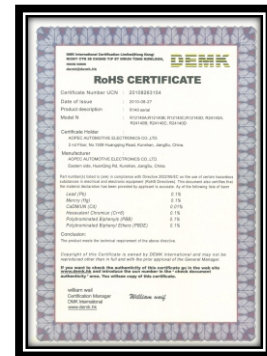

**ROHS**